



**BRUTE**

# HEAVY-DUTY ERGONOMIC 3-SHELF UTILITY CARTS



**MOVE MORE  
MATERIALS EFFICIENTLY**

Most organizations agree that "large time and cost savings opportunities can be found in gaining back mere seconds in operations workflow".<sup>1</sup>

The Heavy-Duty Ergonomic 3-Shelf Utility Carts provide **50% more storage capacity** to help move more materials efficiently throughout a facility.<sup>2</sup>



### CONVENIENT WORK AREA

Designed at the ideal height for light or precision work activities.



### IMPROVED STABILITY

Features two locking casters that keep the cart in place when loading and unloading.



### EXCEPTIONAL DURABILITY

Withstands heavy loads up to 600 lbs.



### CATEGORY-LEADING WARRANTY

Backed by a 10-Year Limited Warranty.

<sup>1</sup>Unlocking Hidden Cost in the Distribution Center

<sup>2</sup>When compared to the surface area of RCP's 2-Shelf Heavy-Duty Ergo Utility Cart Medium (FG452088BLA)



**BRUTE**

# HEAVY-DUTY ERGONOMIC 3-SHELF UTILITY CARTS

## BRUTE HEAVY-DUTY ERGONOMIC 3-SHELF UTILITY CARTS

NO.	DESCRIPTION	TOP SHELF STYLE	COLOR	L x W x H	LOAD CAPACITY	CASE PACK
2203280	BRUTE HD ERGO 3 SHELF CART SMALL	Flat	Black	38.5" x 17.3" x 47"	600 lbs	1
2196862	BRUTE HD ERGO 3 SHELF CART MED	Lipped	Black	41" x 25.3" x 47"	600 lbs	1



2203280

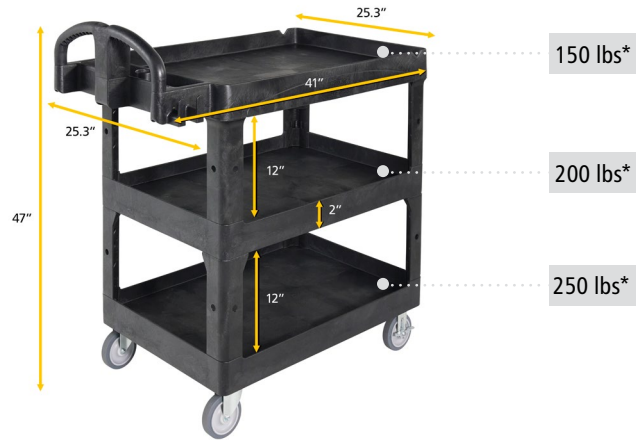

2196862

\*Load capacity per shelf.