



ASSEMBLED PUSH BROOM

The new RCP push brooms offer enhanced features to ensure efficient, hassle-free cleanup for the most demanding commercial jobs.

Features and Benefits:

- Up to 40% higher bristle count* for efficient debris removal
- Thick 1-1/8" wood handle
- Bristles set in solid wood block for added durability
- Fully assembled steel brace and die-cast aluminum connector for strength

*Compared to previous RCP push brooms

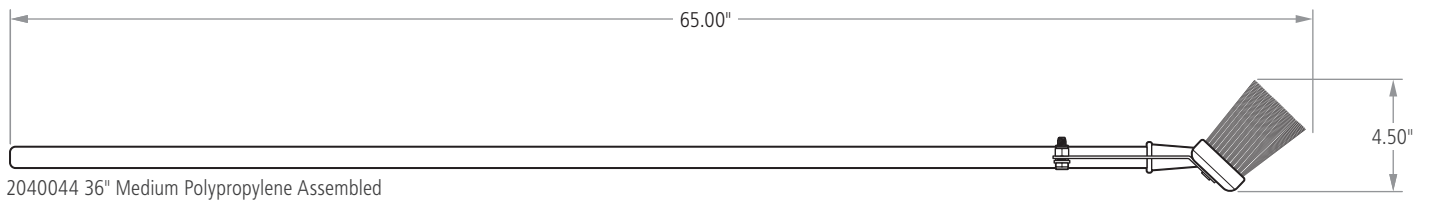
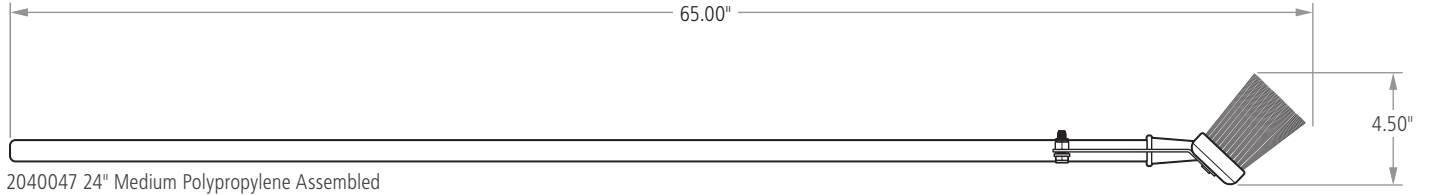
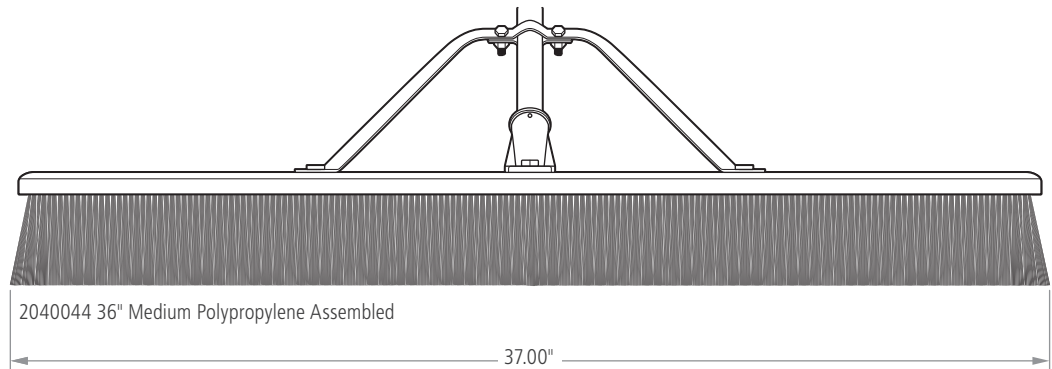
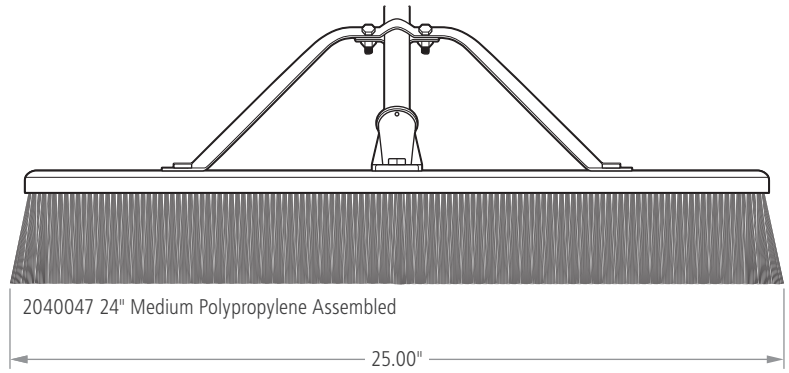

SKU #	DESCRIPTION	BRISTLE TYPE	BRISTLE LENGTH IN	HANDLE	BLOCK	BRACE	CASE QTY
2040052	24" FINE PET ASSEMBLED	FINE PET	4.50"	1-1/8" WOOD	WOOD	STEEL	4
2040049	36" FINE PET POLYPROPYLENE	FINE PET	4.50"	1-1/8" WOOD	WOOD	STEEL	4
2040047	24" MEDIUM POLYPROPYLENE ASSEMBLED	MEDIUM PP	4.50"	1-1/8" WOOD	WOOD	STEEL	4
2040044	36" MEDIUM POLYPROPYLENE ASSEMBLED	MEDIUM PP	4.50"	1-1/8" WOOD	WOOD	STEEL	4
2040043	24" HEAVY DUTY POLYPROPYLENE ASSEMBLED	HEAVY DUTY POLYPROPYLENE	4.50"	1-1/8" WOOD	WOOD	STEEL	4
2040051	36" HEAVY DUTY POLYPROPYLENE ASSEMBLED	HEAVY DUTY POLYPROPYLENE	4.50"	1-1/8" WOOD	WOOD	STEEL	4





The new RCP push brooms offer enhanced features to ensure efficient, hassle-free cleanup for the most demanding commercial jobs.

Features and Benefits:

- Built-in squeegee for convenient debris and liquid removal
- Up to 40% higher bristle count* for efficient debris removal
- Fully assembled steel brace and die-cast aluminum connector for strength
- Broom head is set in a heavy duty resin block that won't warp, rot, or crack under normal usage

*Compared to previous RCP push brooms

ASSEMBLED PUSH BROOM

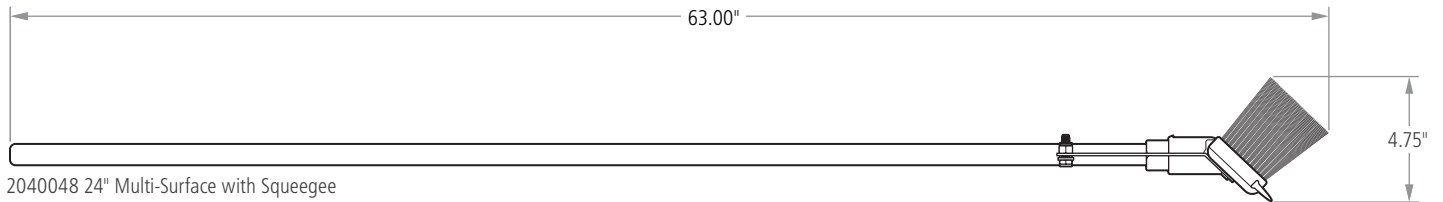
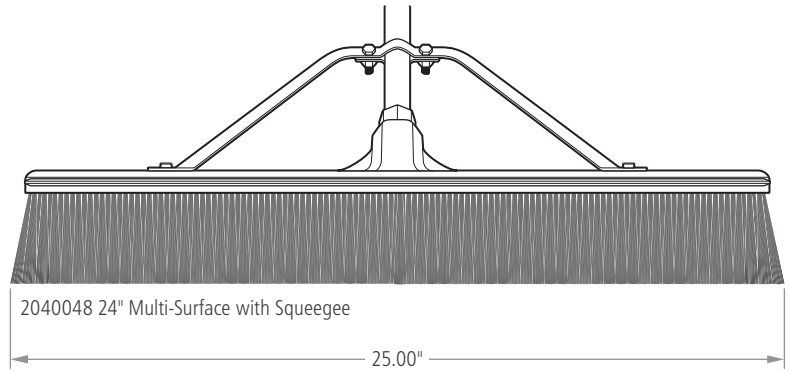

SKU #	DESCRIPTION	BRISTLE TYPE	BRISTLE LENGTH IN	HANDLE	BLOCK	BRACE	CASE QTY
2040048	24" MULTI-SURFACE WITH SQUEEGEE	MULTI-SURFACE	4.75"	15/16" WOOD	RESIN	STEEL	4





The new RCP push brooms offer enhanced features to ensure efficient, hassle-free cleanup for the most demanding commercial jobs.

Features and Benefits:

- Available heavy duty fiberglass handle for extreme durability and weather resistance
- Up to 40% higher bristle count* for efficient debris removal
- Fully assembled steel brace and die-cast aluminum connector for strength
- Bristles are set in a heavy duty resin block that won't warp, rot, or crack under normal usage

*Compared to previous RCP push brooms

ASSEMBLED PUSH BROOM

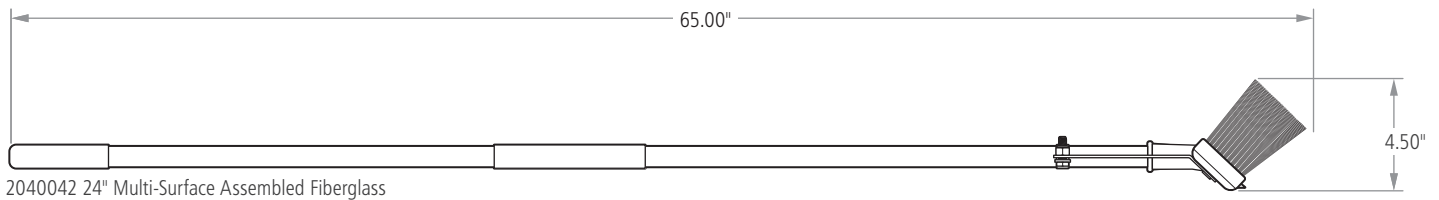
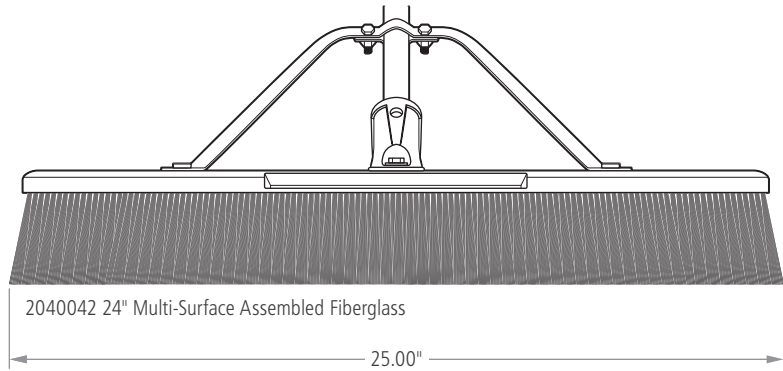

SKU #	DESCRIPTION	BRISTLE TYPE	BRISTLE LENGTH IN	HANDLE	BLOCK	BRACE	CASE QTY
2040042	24\"/>						

